

# Vacuum-Cooking-Cutter K 504



## Vacuum-Cooking-Cutter K 504

The Seydelmann Vacuum-/Cooking-Cutter K 504 offers maximum ease of operation developed according to ergonomical requirements including an extensive equipment. The components of all Seydelmann Machines comply with the up-to-date technical development and contribute to an increase in product quality.

### Facts

Bowl content:	500 Liters
Weight:	6100 kg / 13448 lbs
Loading options:	BW 200, BW 300
Power of motor:	
ultra v:	140 kW / 188 HP
ultra vs:	160 kW / 215 HP
AC-8:	200 kW / 268 HP

## Machine design

The machine frame of the K 504 is almost entirely made of solid stainless steel. All edges are rounded and all surfaces are polished very precisely and designed with a slope enabling cleaning water to drain completely from all surfaces. The embedded covers and the closed bottom with ventilation prevent pollution and water from entering the machine. The knife hood is flow dynamically shaped. Hardly any unchopped product residue is left in the cover. The gap between the knives and the cover or the bowl is very small.

## Applications

Besides the production of boiled-, dry- and cooked sausage, the universally applicable machine is suitable in particular for the chopping, mixing and emulsification of fresh meat, pre-cut frozen meat, cooked meat, fish, vegetables, meat substitute products made from plant-based proteins, fruits, confectionary goods and other edibles at temperatures from -12 °C (10 °F) up to 85 °C (185 °F).

## Vacuum-Function

Cutting under vacuum, a firm emulsion free of air with a volume reduction of 5-7% is produced. Therefore, an even better fineness of the product is achieved. Thanks to the exclusion of air, the final product gains a significantly longer shelf life. A better protein extraction increases the moisture and fat absorption of the product improving the development of the flavour of spices next to the better binding and stability of the final product.

## Cooking-Function

The bowl is heated up by hot steam from a nozzle system installed below the bowl. Enormous time savings can be achieved thanks to cooking and cutting in one step. The production time can be further reduced using an additional heating for the knife hood. An increase of approximately 10% in the volume of the material as well as the complete preservation of taste, aroma and protein is possible. Cooling is optionally available via a nozzle system.



## Maschinenfabrik Seydelmann KG

info@seydelmann.com Tel. +49 (0)711 / 49 00 90-0 Hoelderlinstrasse 9  
www.seydelmann.com Fax +49 (0)711 / 49 00 90-90 70174 Stuttgart, Germany

Cutters · Mixers · Grinders  
Emulsifiers · Production Lines

**Measurements**

- H1 = 930 mm / 36.6 in
- H2 = 3140 mm / 123.6 in
- H3 = 3340 mm / 118.1 in
- T1 = 2160 mm / 131.5 in
- T2 = 2720 mm / 107.0 in
- B1 = 2540 mm / 100.0 in
- B4 = 3500 mm / 138.0 in
- X = 1980 mm / 78.0 in

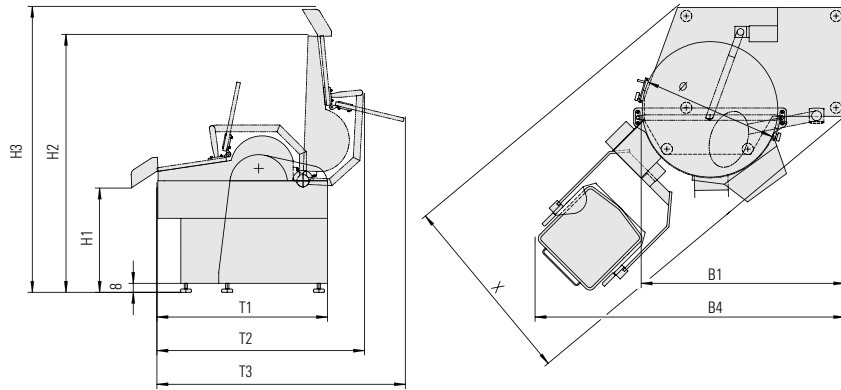

Knife head



Temperature sensor



Auto-Command 4000 (optional)

**Standard equipment**

- Vacuum- and/or Cooking-Function
- Operation via cross lever switches
- Changeable and balanceable knife head
- Hydraulic main cover, absorbing cover and ejector
- See-through noise absorbing cover made of special plastic
- Separate electrical cabinet made of stainless steel with integrated main switch
- Pneumatic locking of knife shaft arm
- Switch-off for temperature and operating time
- Temperature sensor
- Noise insulation
- Greasing point

**Additional equipment**

- Hydraulic loading device
- Loading device for loading trolleys BW 300
- Control of unbalanced state
- Various knife systems
- Automatic knife shaft balancing system
- Frequency controlled stepless bowl
- Up to 9 switch-offs for temperature and operating time
- Variable adjustment of knife speed (only with AC-motor)
- Water nozzles with water meter
- Liquids dosing system with nozzle
- Direct steam
- Nitrogen input for gas flushing
- Liquid Nitrogen (LN<sub>2</sub>) or carbon dioxide (CO<sub>2</sub>) input for cooling
- Cover heating / -cooling
- Fast clamping nut for knives
- Ejector with variable speeds
- Lock of noise absorbing cover
- Cover damping for noise absorbing cover
- Noise insulation version

**Control: Auto-Command 1000**

- 21,5" touch wide-screen LED color display
- Stainless steel housing
- Computer based automatic control
- Display of all technical parameters
- Program control
- 30 programs with up to 10 steps each
- Switching off or on when reaching up to 9 pre-programmable temperature or time values
- User-friendly logical design
- Display of maintenance and service intervals

**Optional Auto-Command 2000, 3000, 4000**

- 24.0" touch wide-screen LED color display
- Waterproof design IP 69
- Advanced recipe control with display of required ingredients and recipes
- User management
- Data recording
- Production plan
- Second workstation outside the production room possible
- Connection to MES or ERP systems possible

**Motor types**

**AC-8**

- 6 steplessly programmable knife speeds
- 2 reverse mixing speeds
- 2 separate bowl speeds
- Frequency-controlled 3-phase motor

**Ultra**

- 2 knife speeds
- 2 forward mixing speeds
- On request: 2 reverse mixing speeds
- 2 separate bowl speeds
- All drive systems with 3-phase motors